

INSTALLATION GUIDE

Classical cast iron rainwater
& gutter systems



cast iron outlet

INSTALLATION ADVICE

The purpose of this guide is to provide detailed information and clear instructions to assist the installer, with methods, to simplify the installation being achieved.

Its objective is to provide the user with all the necessary advice to ensure a trouble-free and quality installation. For full product range see product manual.

TECHNICAL/PLUMBING ADVISORY SERVICE

In support of Cast Iron Outlet plumbing advisory service is available to customers to provide technical assistance and guidance on installation. Tel : 03300244884

ENQUIRIES/SALES:

Cast Iron Outlet

email: enquiries@castironoutlet.co.uk

www.castironoutlet.co.uk

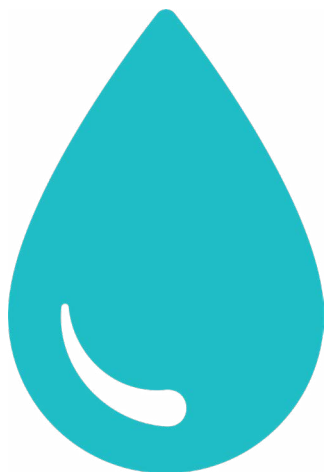

GENERAL

When working on gutters or fascias at height it is advisable to use scaffolding in preference to ladders. If you are using a ladder please take the following points into consideration: (These points are for guidance only).

1. Ensure the ladder is based on level ground, preferably not soil or grass. If the ladder is based on soil or grass then place a board beneath the legs to spread the load and prevent sinking.
2. If possible, tie the top of the ladder to ring bolts at eaves level. Before fitting pipes/gutters, ensure that all pieces have been primed and painted, including all cut ends to prevent corrosion. If any pipes/gutters have been cut/drilled, ensure that there are no loose filings on the system as these will quickly discolour the product.
3. We strongly recommend that you do not work alone. Removal and installation of cast iron guttering generally requires two people. Before replacing an existing system it is advisable to inspect and repair fascia and wall faces before beginning a new installation. All fascias must be in good condition before new guttering is installed as the weight of the cast iron gutters could cause rotten fascias to fall causing damage or injury to property or persons below. If the building does not have fascia boards, contact your local builders merchant for advice on suitable support brackets, or contact our Technical Advisory department on 03300244884.



GUTTER INSTALLATION

When working on gutters or fascias at height it is advisable to use scaffolding in preference to ladders. If you are using a ladder please take the following points into consideration: (These points are for guidance only).

STEP 1

Identify route which rainwater will take.

STEP 2

Locate gully/connection to drain and position outlet, taking into account offset projection. (Fig. 1)

STEP 3

Approximately 75mm - 100mm from the end of the run fit a bracket, taking into account the fall down to the outlet.

Note: For other brackets see “General Notes” (Page 1).

Fix the remaining gutter brackets at maximum centres of 900mm (more frequently in areas prone to high snowfall) along the fall line (as shown in Fig. 2). Additional brackets should be fitted at a maximum of 150mm from angles and outlets (as shown in Fig. 3).

Brackets should be fixed using corrosion resistant wood screws 5mm x 25mm round or pan headed. Use plumbline or string for alignment when bracketing.

Note: When using OG and moulded proles, we recommend that fascia brackets are used wherever possible.

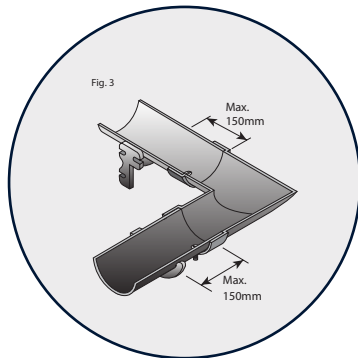
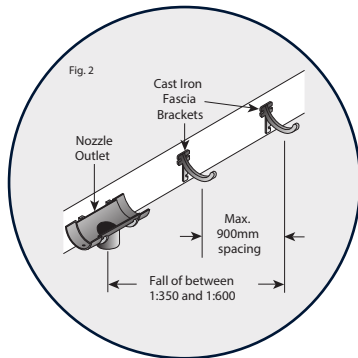
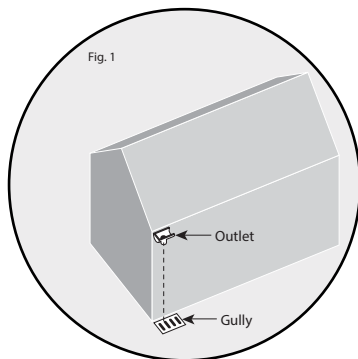

STEP 4

Ensure brackets are installed so that centre of gutter is beneath the tile edge. (Fig. 4)

See installation advice, general re: Fascia Board (Page 1).

STEP 5

Position gutters loosely within brackets and assess installation for fall and offset position to rainwater pipe. Make adjustments as required. (Fig. 5)

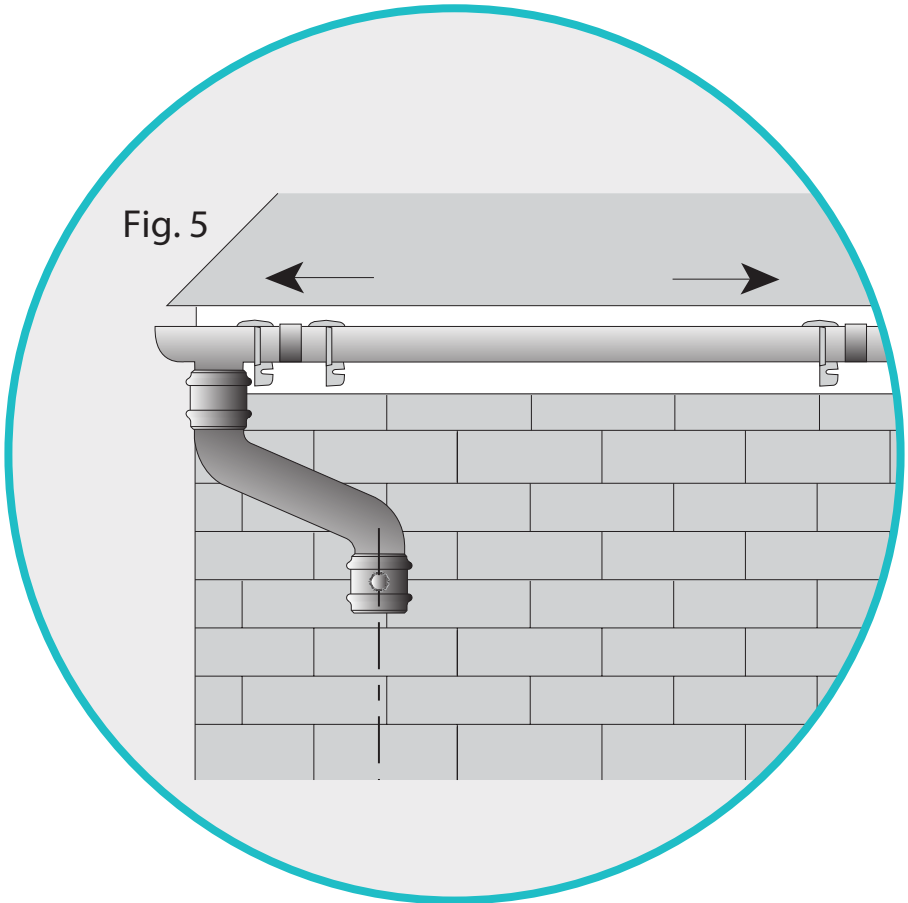
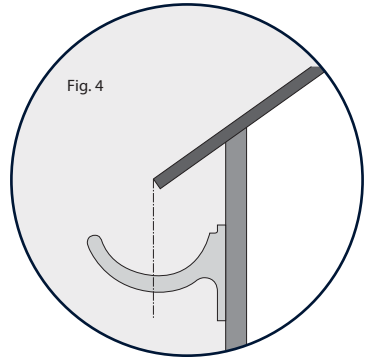

JOINTING HALF ROUND PROFILE

If installing Half Round Profile Gutters, The Cast Iron Jointing Kit (Product Code 192284) can be used as an alternative to the traditional method. Kit contains enough materials to seal 20 Half Round Gutter Joints (and is suitable for the 100, 115 and 125mm HR sizes. (For 150mm HR, see Fig. 10).

STEP 1

Push screw through spigot of gutter or fitting and then through the hole in the gasket material. The hole in the gasket is a tight fit and will locate on the screw while the joint is being made. (Fig. 6)

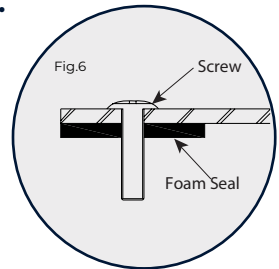

STEP 2

Locate the screw, seal and spigot of the gutter or fitting into the socket of the gutter or fitting and fix square nut and washer to the end of the screw. (Fig. 7)

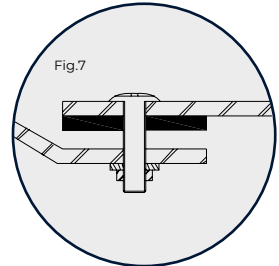

STEP 3

Ensure the seal is sitting squarely in the socket and tighten the nut on the screw.

Note: It may be necessary to hold the screw with a screw driver as the seal is compressed. (Fig. 8)

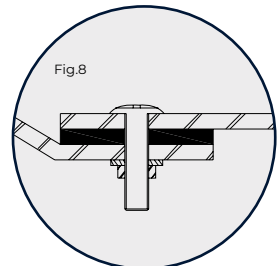

STEP 4

Trim excess rubber at the edge of the joint with a sharp bladed knife. (Fig. 9)

STEP 5

Paint gutters, joint and screws to the equivalent standard of the finish coat.

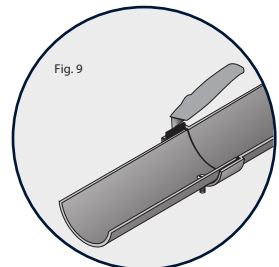

BEADED HALF ROUND, DEEP HALF ROUND, MOULDED NO.46, OG

STEP 1

Gutter sockets should be joined to spigots with a specialist rubberised bitumen gutter sealant or a low modulus silicon sealant, then fixed with a corrosion resistant round/pan head setscrew and nut, M6 x 20mm long. (Fig. 10)

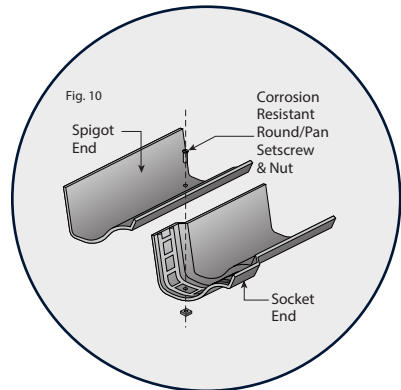

STEP 2

Spread sufficient sealant within the socket, applying additional sealant under the head of the setscrew, when bringing the parts together. The nut should then be finger tightened. Any excess that appears should then be removed. Allow the sealant to 'cure' and then tighten the nut and bolt. Do not over-tighten as this could damage the gutter. (Fig. 11)

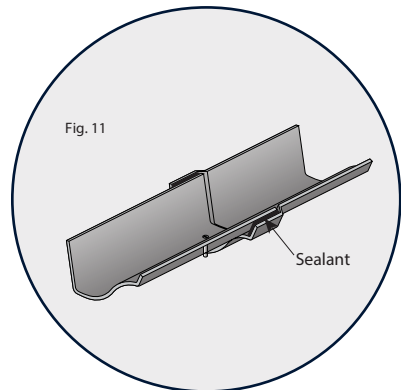

Repeat this procedure for all joints. See notes regarding replacement gutters.

Note:

Before installing gutters and fittings, ensure that all pieces have been suitably painted. See painting finish methods. If any gutters have been cut, ensure that there are no loose filings on the system as these will quickly discolour the product.

DRILLING GUTTERS

Hole size is 8mm (5/16") and should be positioned centrally 20mm from the spigot of the gutter (Fig. 17).

The hole in a fitting socket will provide a useful template. We recommend the use of tungsten tipped drills or a good quality masonry drill.

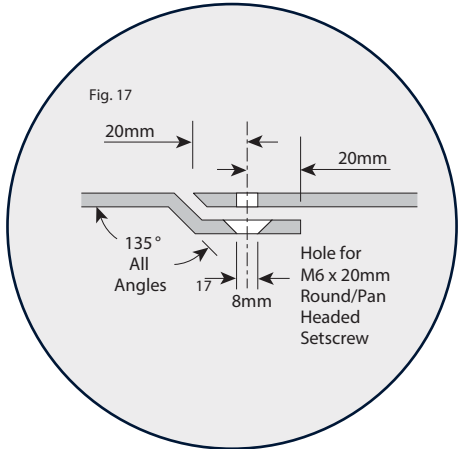

CUTTING

Locate gutters can be cut using a hacksaw, the blade should be tungsten tipped with 50 teeth per inch. A powered saw or disc cutter can be used.

Note: Please observe the necessary safety precautions recommended by the tool manufacturer. (Fig. 18)

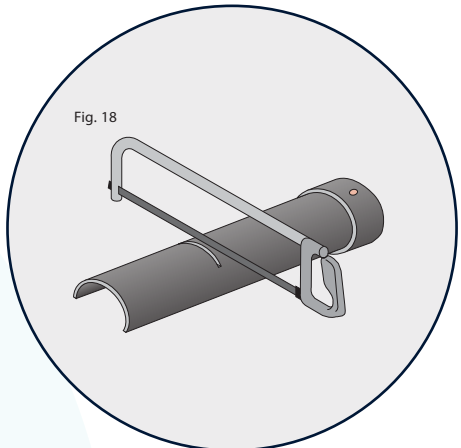

PIPE INSTALLATION

(BOTTOM UP)

STEP 1

Using plumbline from centre of nozzle/offset, determine position of shoe or connection to drain.

(Fig. 19)

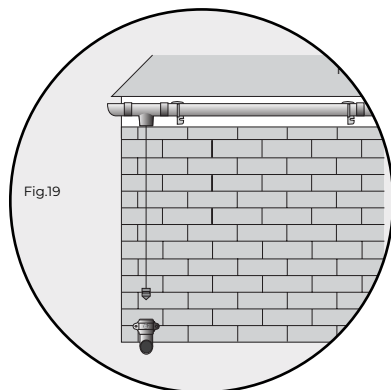

STEP 2 (EARED PIPE)

Determine the position of the fixings and drill suitable holes to take rawlplugs or anchors. 8mm x 50mm min.

Non-corrosive fixing should be used without wall spacer plate, 8mm x 75mm min.

Non-corrosive fixing with wall spacer plate.

(Fig. 20)

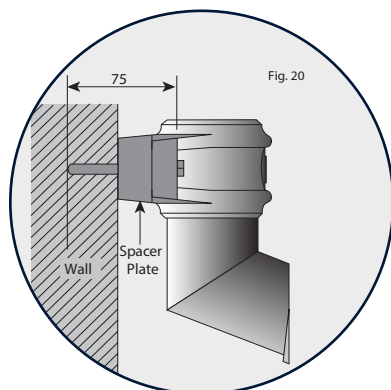

Note: Cast iron spacer plates may be required if wall is uneven and will also allow for easier maintenance. These should be fixed with the flat back plate to the back of the pipe ear.

STEP 3:

The pipe spigot is offered into the shoe socket and positioned in line with the plumbline, hole centres are then marked through centre of elongated holes in ears, this will allow for adjustment.

(Fig. 21)

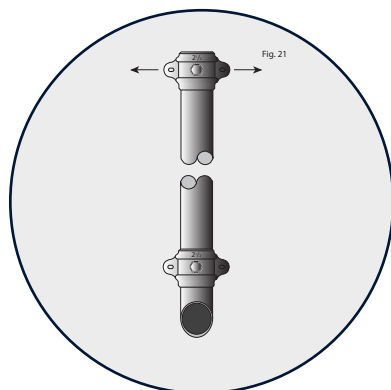

STEP 4

Drill and fix as shoe.

STEP 5

Repeat until last full length is fixed, ensuring in each case that the pipe spigot is fully seated in supporting socket.

STEP 6

The last pipe length should be measured from the internal base of the socket to the underside of the gutter nozzle (A), or to the spigot of the offset (B), remembering to include the depth of socket in overall length. (Fig. 22)

STEP 7:

Cut pipe to length allowing 5mm for clearance on length and fix as previously described.

Note: It may be necessary to lift gutter to locate nozzle in the pipe socket.

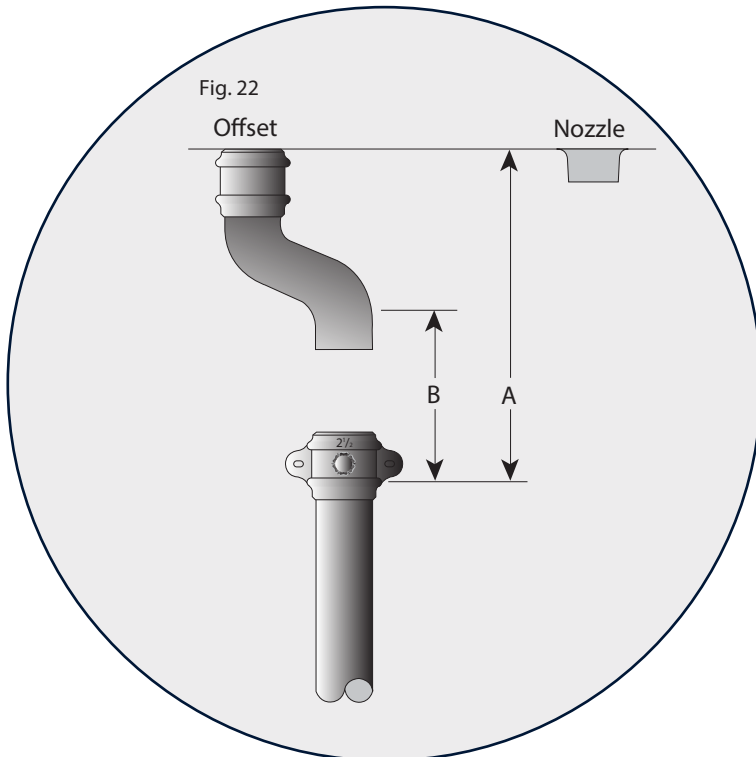

STEP 8

Finally, to centralise and secure pipe joints, use wedges made up from sheet lead cut into 30mm strips, rolled and tapped, between socket and pipe. This should be inserted in 3 places to avoid any rattle. (Fig. 23)

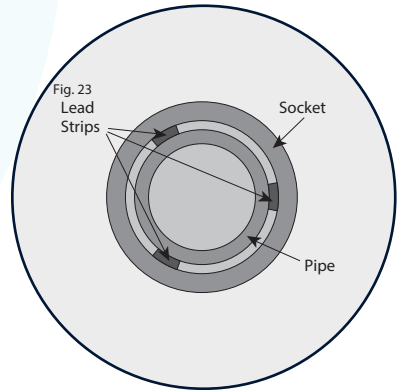

UNEARED PIPE FIXING

These can be fixed using a drive in spike (tradename, holdfast), wrought iron or galvanised mild steel. (Fig. 24)

A wall fixing bracket made in galvanised mild steel can also be used by drilling suitable holes and inserting rawlplugs to take 50mm (depth) screw. The bracket will then be located to the back plate supplied. (Fig. 25)

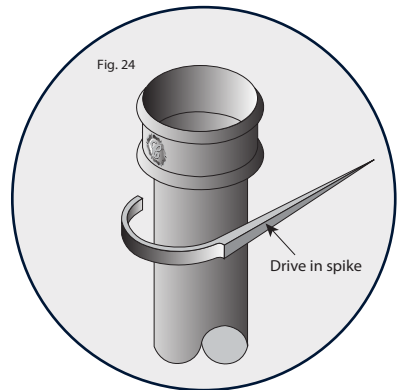

Note: For rectangular pipes, a cast iron decorative ear band can be supplied for fixing pipes to the wall.

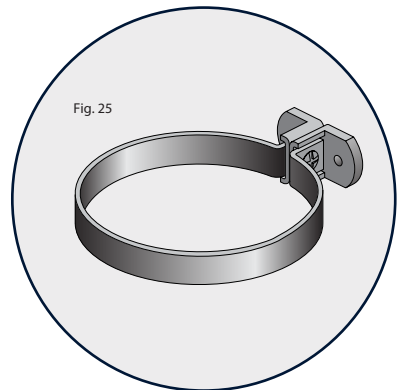

LOOSE SOCKETED PIPE FIXING (BOTTOM UP)

Installation is as for Classical fixed socketed pipe, the loose socket, however, is loosely inserted into the pipe before establishing fixed centres. The socket will perform without the need for filling in the vertical position, but if preferred a suitable low modulus sealant or filler can be used.

To establish pipe length required, loosely insert socket and **follow Step 6 in Fixed Socket Section.**

Note: Allowances for socket depths, refer Dimension A.
(Fig. 26)

In a situation where the connection at the base of the rainwater stack runs into the drain inlet, a galvanised steel wall fixing bracket or eared access pipe (100mm only) will be required to retain pipe barrel.
(Fig. 27)

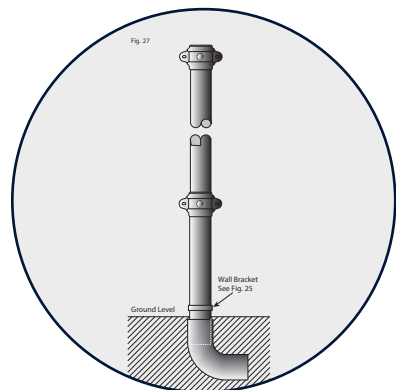
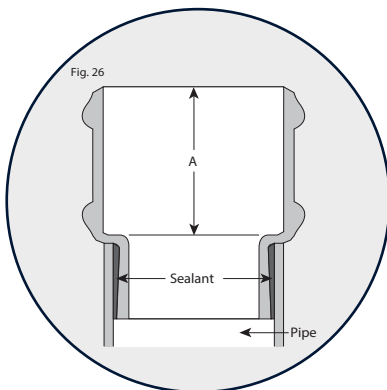

TOP DOWN FIXING (FIXED SOCKET)

This is the reverse procedure to the previous section. The first pipe to be fixed is positioned and marked relative to the offset/gutter nozzle. (Fig. 28)

The process is repeated up to the last full pipe length. The pipe at the base of the stack will have to be cut to length relative to the shoe.

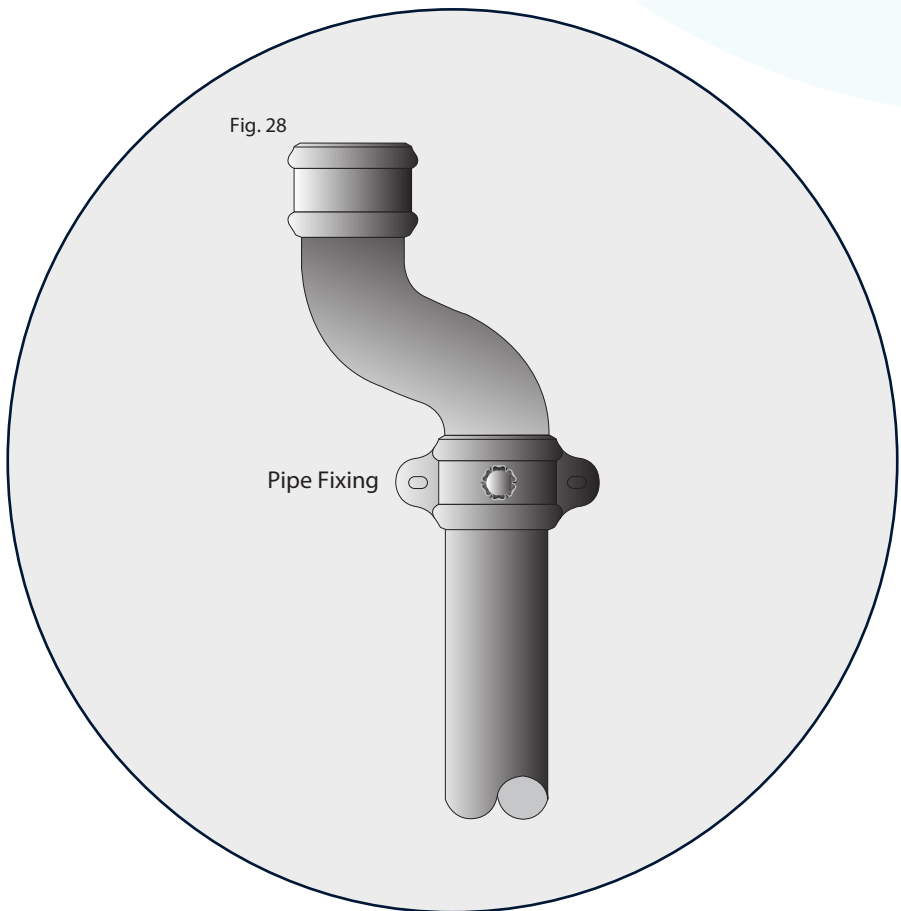

LOOSE SOCKETED PIPE FIXING (TOP DOWN)

STEP 1

The loose socket is located and fixed so that it fully supports the offset, or is located beneath the nozzle.

STEP 2

A pipe barrel is then inserted into the inlet of the loose socket.

STEP 3

Both pipe and socket are then offered to the fixed socket spigot ensuring that the pipe end is located to the underside of the fixed socket.

STEP 4

Holes on the loose socket are marked, drilled and socket is then fixed.

STEP 5

This is repeated until stack is completed.

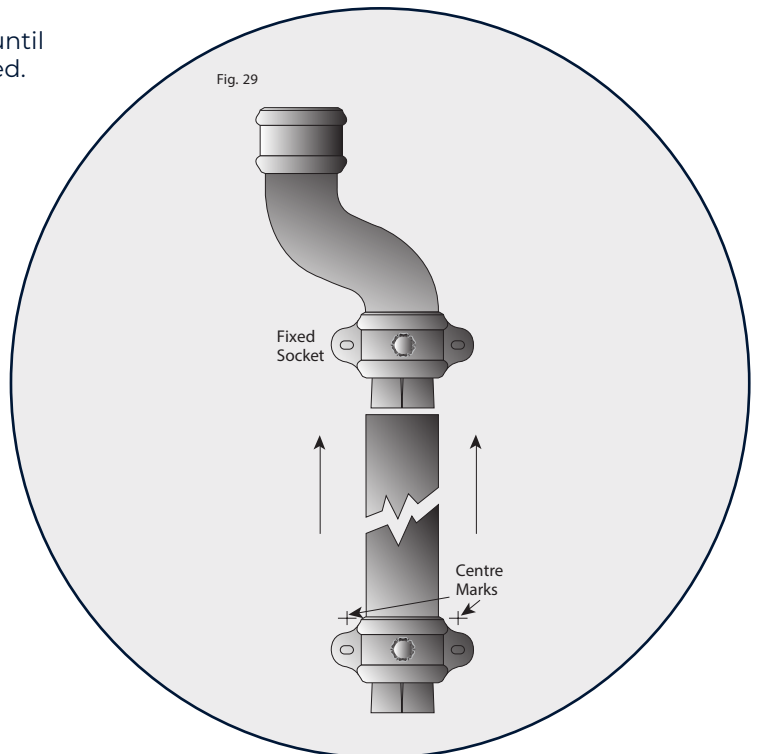

ADDITIONAL INFORMATION

MAKING UP OFFSETS

When the projection of the fascia is in excess of 455mm the offset is formed with a pipe offcut, and two 112 1/2 bends (Fig.30)

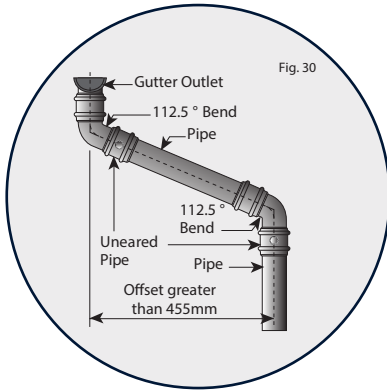

SEALING PIPE JOINTS

With vertical pipes, joints are usually left unsealed in the sockets so that if any blockages occur the rainwater pipe does not fill up with water to the eaves and create a nuisance. Only seal joints between gutter outlet and rainwater pipe or offset. (Fig. 31)

Also, any joint which is in the horizontal position such as 90° Branch arms or Bends etc.

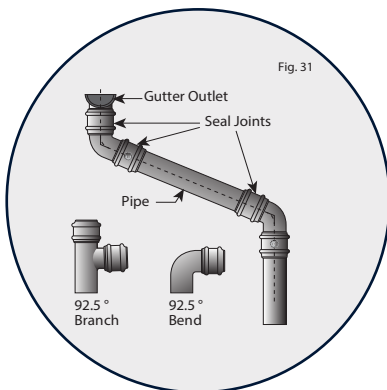

CUTTING PIPE

How do you cut a length of cast iron pipe or gutter?
With pipe there are three methods.

Firstly the easiest and quickest way is by using a powered disc cutter or metal saw (as shown here Fig. 32).

Secondly, by pipe wheel cutter, which takes slightly more time but gives a neat square edged cut.

Thirdly, by hacksaw, although a tungsten tipped or 50 TPI blade is usually required.

Note: Snap cutters are not recommended for use on cast iron pipes etc., and safety equipment, for instance eye protection, should be worn at all times. Always follow guidelines laid down in health and safety regulations.

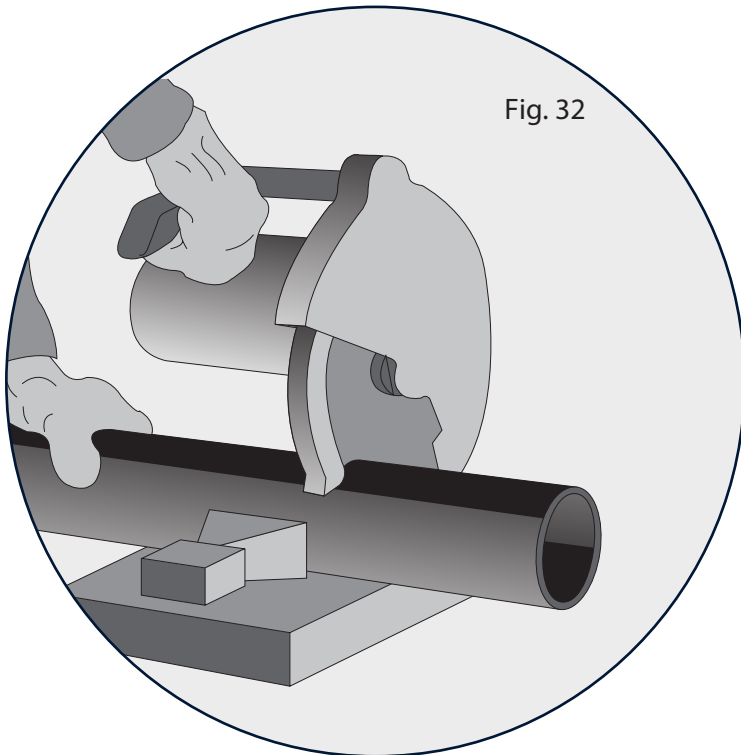

PAINTING/FINISH METHODS

Classical cast iron rainwater systems are supplied in a black primer coating or in “Plus” finish (a semi-gloss, black topcoat) - available on standard HR and Ogee gutters and fittings and circular downpipes and fittings. Painting - (on site, prior to installation)

When preparing the pipe, gutter and fittings for the onsite finishes, inspect the products, wire brush and touch up the factory applied primer coating, with a metal primer, (if and where necessary) after first ensuring all surfaces are degreased with thinners and are dust free.

Apply an undercoat (usually 2 coats), before finishing the product with a top coat to suit the building decor. We recommend that only a suitable, good quality paint finish is used to ensure minimal maintenance. Please note that extra care should be given where cast iron is being installed in exposed coastal areas. Always consult paint manufacturers' recommendations. Some exterior paints may not be suitable for painting over the water-based primer. We do not accept any responsibility for the performance of any customer-applied, finished coat systems. It is the responsibility of the installer/purchaser to examine and repair any coating damage to the factory-applied primer coating, before applying further primer and top coats prior to installation.

CLASSICAL PLUS (Finish Coat)

Product is supplied wrapped to protect from physical damage. Following installation it is important that any slight installation damage to the coating is repaired with the appropriate quick drying touch up paints available. **Product Code 192549 (Primer) and 192550 (Top Coat).**



PAINTING/FINISH METHODS

Cast iron rainwater gutter systems are designed and manufactured to give many years of reliable service, but to achieve this, regular inspection and minimal routine maintenance should be carried out including:

1. Annually check and clear the gutter systems & rainwater heads of any leaves and debris that could cause a potential blockage (may require more checks if in close proximity of trees etc).
2. Also inspect the condition of the paintwork at the same time as 1. wiping clean any film built up, to protect the surface finish.
3. Also check on security of fixings and joints. If the manufacturers installation and paint suppliers instructions are adhered to re-painting should not be required for approx 5 years or longer.
(Unless subject to aggressive atmospheric conditions i.e. coastal towns and providing the integrity of the finish coat is maintained).















EQUIPMENT REQUIRED











TOOLS:

- Drill
- Screwdriver
- Adjustable Spanner
- Hacksaw - Disc Cutter
- Wirebrush
- Plumblines
- Pencil/marker
- Ladder
- Scaffold
- Paint Brush
- Scraper
- Spirit Level
- Tape Measure









MATERIALS:









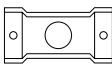

- Classical gutters and rainwater fittings etc.
- Paint-metal primer undercoat, top coat
- Mastic Sealant - low modulus (suitable for overpainting) or Plumbers' Mate
- Setscrews and Nuts (gutter bolts 6mm x 25mm long)
- Wall anchors for pipe sockets (50-75mm min. length)
- Lead strips - to wedge in sockets
- Round headed woodscrews (5mm x 25mm long)
- Round/Pan headed setscrews (6mm x 20mm long)

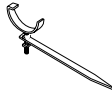
PRODUCTS		SIZES	
CLASSICAL RAINWATER PIPES (A585)			
	Single Socket Eared (overall length) 1829mm 1829mm 1829mm	65 75 100	
	Single Socket No Ears (overall length) 1829mm 1829mm 1829mm	65 75 100	
PLAIN BARRELS			
	(overall length) 1750mm	65 75 100	
LOOSE SOCKETS (A586)			
	Eared / No Ears	65	
	Eared / No Ears	75	
	Eared / No Ears	100	
WALL SPACER PLATE (A584)			
	Cast iron - for use with eared pipes and shoes	65 75 100	
SHOES FRONT (A588)			
	Eared / No Ears Eared / No Ears Eared / No Ears	65 75 100	
RAINWATER DIVERTER KIT (A593)			
	No Ears / No Ears No Ears / No Ears	65 75	
ACCESS PIPE (A590)			
	Eared / No Ears Eared / No Ears Eared / No Ears	65 75 100	
BENDS (A591)			
	92 1/2° 92 1/2° 92 1/2°	65 75 100	
	112 1/2° 112 1/2° 112 1/2°	65 75 100	
	135° 135° 135°	65 75 100	
BRANCHES (A592)			
	92 1/2° 92 1/2° 92 1/2°	65 75 100	
	112 1/2° 112 1/2°	65 75	
	135° 135°	65 75	

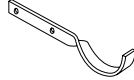
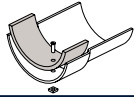





PRODUCTS		SIZES	
OFFSETS (A594)			
	75 projection 75 projection 75 projection 115 projection 115 projection 115 projection 150 projection 150 projection 150 projection	65 75 100 65 75 100 65 75 100	
	225 projection 225 projection 225 projection 305 projection 305 projection 305 projection 380 projection 380 projection 380 projection 455 projection 455 projection 455 projection	65 75 100 65 75 100 65 75 100 65 75 100	
GALVANISED STEEL WALL-FIXING BRACKET (A548)			
		65 75 100	
DRIVE-IN SPIKE (A459)			
		65 75	
CLASSICAL PIPES (A601)			
	Square & Rectangular Eared and No Ears Associated fittings	100 x75	
HEADS			
	Flat Hopper (A750) 210 x 160 x 185 210 x 160 x 185 250 x 215 x 215	65 75 100	
	Flat Hopper (A751) 305 x 186 x 200 305 x 186 x 200	65 75	
	Flat Rectangular Box (A841) 225 x 125 x 125 225 x 125 x 125 Flat Rectangular Box (A842)	65 75 100	
	Rectangular (A484) 300 x 250 x 200 300 x 250 x 200 300 x 250 x 200	65 75 100	
	Castellated Rectangular (A485) 250 x 180 x 175	65	
	Rectangular (A485) 250 x 180 x 175 250 x 180 x 175	75 100	

These products are available primer coated or "Plus" finish

PRODUCTS		SIZES
HR GUTTER & CONNECTIONS		
	Half Round Gutter (G800) 1829mm 1829mm 1829mm 1829mm	100 115 125 150
	Right Angle Double Socket (G802D) 90° 90° 90°	100 115 125
	Right Angle Single Socket (G801) 90° 90° 90° 90°	100 115 125 150
	Left Angle Single Socket (G802) 90° 90° 90° 90°	100 115 125 150
	Right Angle Single Socket (G801) 135° 135° 135° 135°	100 115 125 150
	Left Angle Single Socket (G802) 135° 135° 135° 135°	100 115 125 150
UNION CLIP (G803)		
		100 115 125 150
STOPEND FOR SPIGOT (G804)		
		100 115 125 150
STOPEND FOR SOCKET (G805)		
		100 115 125 150
NOZZLE (G806)		
	65mm outlet 65mm outlet 65mm outlet 75mm outlet 75mm outlet 75mm outlet 75mm outlet 75mm outlet 100mm outlet	100 115 125 100 115 125 150 150 150

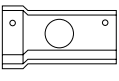
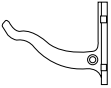
PRODUCTS		SIZES
HR GUTTER & CONNECTIONS		
	Dropend with socket (G807) 65mm outlet 65mm outlet 75mm outlet 75mm outlet 100mm outlet	100 115 125 150 150
	Dropend with spigot (G808) 65mm outlet 65mm outlet 75mm outlet 75mm outlet 100mm outlet	100 115 125 150 150
	Fascia Bracket (G809)	100 115 125 150
	Rise & Fall Bracket (G872) Black coated mild steel Note - requires painting after fixing	100 115 125 150
	Rafter Bracket (G871) Top x Galv. mild steel	100 115 125 150
	Rafter Bracket (G870) Side x Galv. mild steel °	100 115 125 150
	Cast Iron Gutter Jointing Kit (G873) Side x Galv. mild steel °	100 115 125
OG GUTTER & CONNECTIONS (G840)		
	1829mm length	100 115 125
	Angle Internal (G841) 90° 90° 90°	100 115 125
	Angle Internal (G841) 135° 135° 135°	100 115 125
	Angle Internal (G842) 90° 90° 90°	100 115 125
	Angle Internal (G842) 135° 135° 135°	100 115 125

These products are available primer coated or "Plus" finish

PRODUCTS		SIZES
UNION CLIP (G844)		
		115 125
STOPEND FOR SOCKET (G844)		
		115 125
STOPEND FOR SPIGOT (G845)		
		115 125
NOZZLE (G846)		
	65mm outlet 65mm outlet 65mm outlet 75mm outlet	115 125 125 125
FASCIA BRACKET (G849)*		
		115 125
OTHER GUTTER PROFILES		
	Deep HR Gutter & Connections (G810)	125x75
	3mm Thick HR Double Beaded Gutter & Connections (G820)	115 125
	Moulded Gutter & Connections (G830)	100x75 125x100 150x100

DIMENSION (SIZE) KEY:
PIPE
65mm - 2 1/2" imperial size 75mm - 3" imperial size 100mm - 4" imperial size 100 x 75mm - 4" x 3" imperial size
GUTTER
100mm - 4" imperial size 115mm - 4 1/4" imperial size 125mm - 5" imperial size 150mm - 6" imperial size 100 x 75mm - 4" x 3" imperial size 125 x 75mm - 5" x 3" imperial size 125 x 100mm - 5" x 4" imperial size
Half Round and common Ogee gutters and connections are manufactured in accordance with BS 460. All products are supplied in a black primer coating.

These products are available primer coated or "Plus" finish





cast iron outlet

For more information, please visit our dedicated website:

www.castironoutlet.co.uk

Technical Enquiries

Tel: 03300244884

Email: enquiries@castironoutlet.co.uk

- Systems designed in accordance with BS 460:2002+a2:2007
- Quality Management Systems BS EN ISO 9001:2015
- Occupational Health & Safety Management System ISO 45001:2018
- Environmental Standard BS EN ISO 14001:2015
- Energy Management System BS EN ISO 50001:2019

The information given in this literature is, to the best of our knowledge, correct at the time of going to print. However, Cast Iron Outlet is constantly looking at ways of improving their products and services and therefore reserve the right to change, without prior notice, any of the data contained in this publication. Any orders placed will be subject to our Standard Conditions of Sale, available on request.